

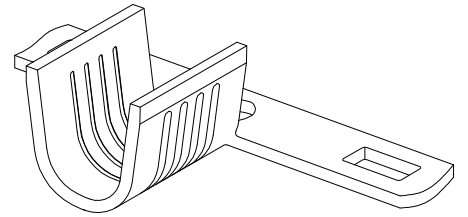

Bu Çizim MESA OTO ELEKTRİK LTD.ŞTİ'nin malıdır. Şirket Yetkilerinin izni olmaksızın kopya edilemez, üzerinde değişiklik yapılamaz.
This Drawing MESA AUTO ELECTRIC LTD 's are property. Can not be copied without the consent of the company authorized, any changes can be made.

| PARÇA KODU PART CODE | PARÇA ADI PART NAME | s ÖLÇÜSÜ (KALINLIK) s MEASURE (THICKNESS) | Malzeme Material | Kaplama / Coating | | |
|-------------------------|-------------------------------|--|-------------------------|-------------------|----|----|
| | | | | SN | AG | Ni |
| TEK 2860 RP | EK BİRLEŞTİRME (TKT 77) =RP= | ----- | (CuZn30) Pirinç / Brass | - | - | - |
| TEK 2860 RPK | EK BİRLEŞTİRME (TKT 77) =RPK= | ----- | (CuZn30) Pirinç / Brass | + | - | - |

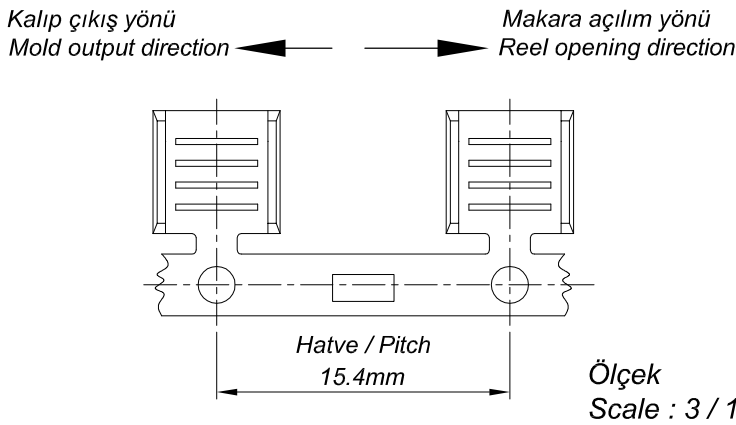
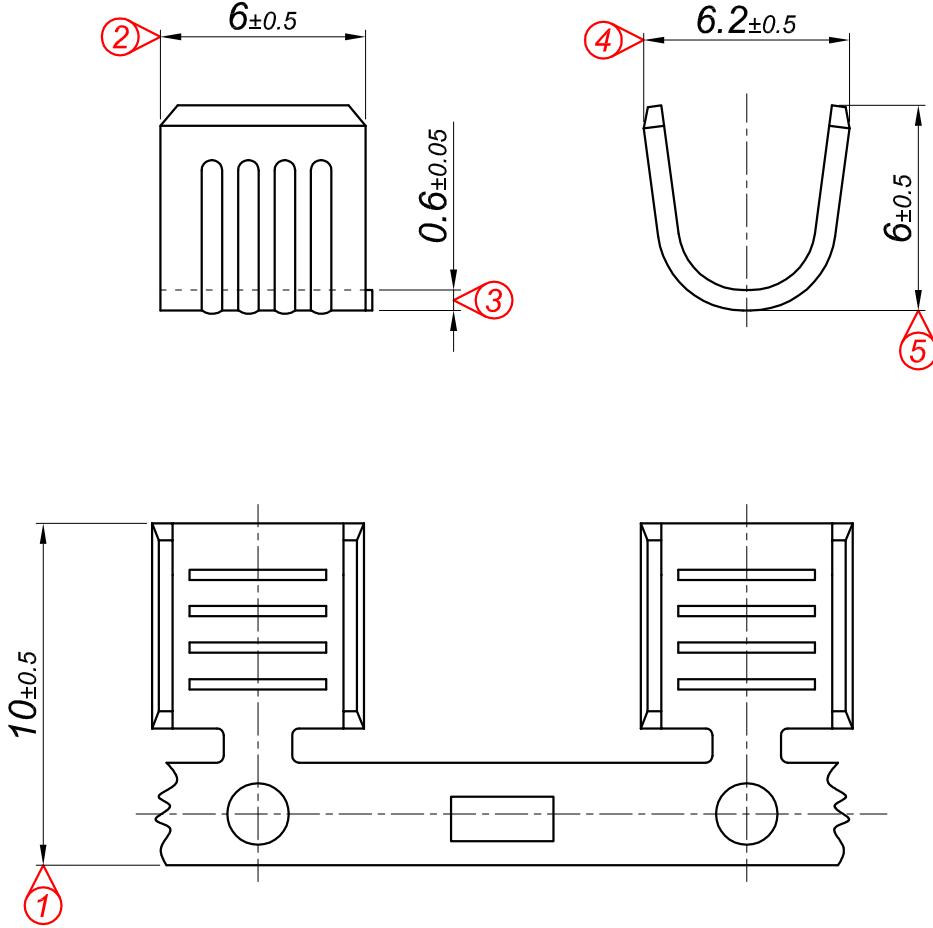

Kablo Kesiti
Wire Section : 4 - 6 mm²

Resmin Üzerinden Ölçü Almayınız
Don't use the drawing for measuring purpose

| Tarih / Date | 28.11.2013 | İmza /Signature | Ölçek / Scale | | |
|---|-------------------------|-------------------------|--------------------------|----------|-----------------------|
| Çizen / Desing | M.Yağcı | | 5 / 1 | | |
| Onay / Approval | S.Gölcük | | | No | Değişiklik / Revision |
|  | Parça Adı: Part Name | EK BİRLEŞTİRME (TKT 77) | Parça Kodu: Part Code | TEK 2860 | |